

ANGLE 1

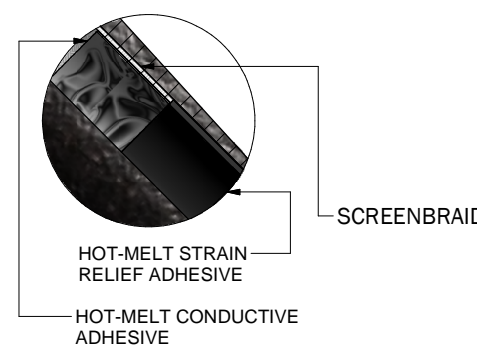
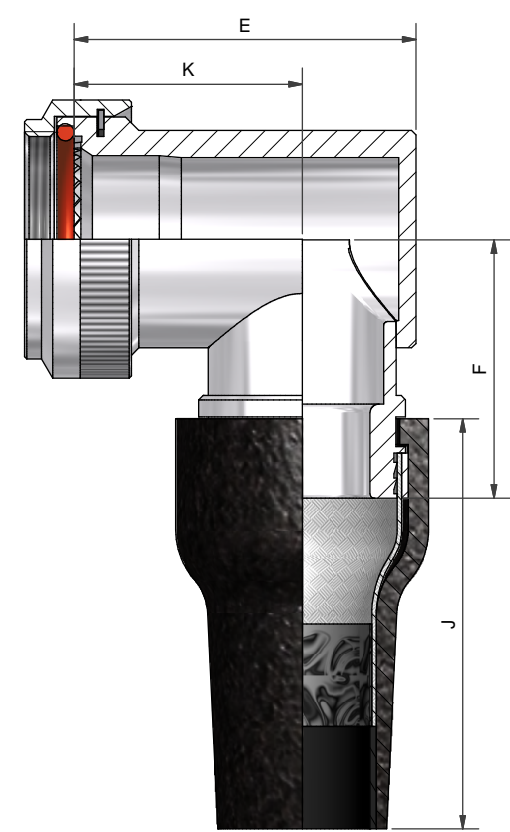
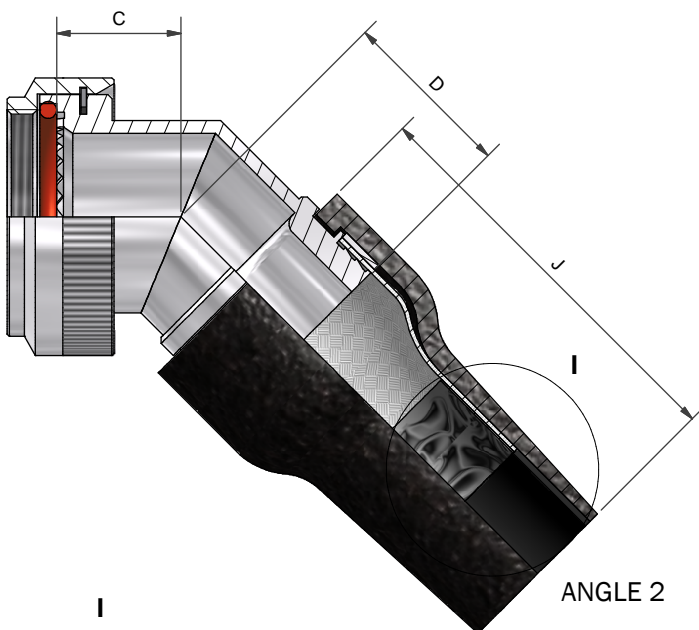
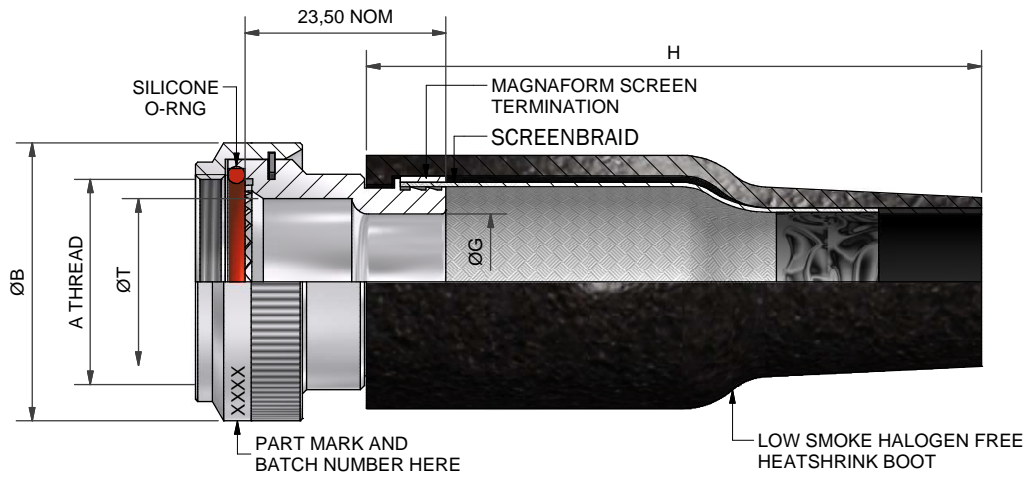

DRAWN	J.CLARK	DATE	04/10/2010	3RD ANGLE PROJECTION NOT TO SCALE	POLAMCO WESTON LOCK LOWER BRISTOL ROAD BATH BA2 1EP	PAGE 1 OF 2	UNLESS OTHERWISE SPECIFIED ALL DIMENSIONS IN MILLIMETRES
SALES APPR							
DESIGN APPR	K.SHEP	DATE	25/05/2009	THIS DRAWING IS COPYRIGHT AND THE PROPERTY OF POLAMCO LTD IT MUST NOT BE COPIED, USED FOR MANUFACTURE OR OTHERWISE DISCLOSED WITHOUT PRIOR WRITTEN CONSENT OF THE COMPANY.	ASSY USED ON: MIL-DTL-38999 SERIES III & IV TITLE: HEAT SHRINK BACKSHELL KIT	MATERIAL ALUMINIUM ALLOY 6262	NCAGE CODE U5792
QUAL APPR							
ISSUE 4		DCR	3969				
WEIGHT		GENERAL TOL	LINEAR +/-0.1MM ANGULAR +/- 1°	PART NUMBER:	TAKH SERIES	DRAWING NO:	P13852

TABLE 1

SHELL SIZE	A THREAD	ØB MAX	ØT MIN	C MAX	D ±0,5	E MAX	F MAX	K ±0,5
09	M12 x 1,0	18,0	6,7	13,1	17,1	25,7	24,0	17,5
11	M15 x 1,0	21,0	10,2	13,9	18,2	26,7	25,7	17,5
13	M18 x 1,0	24,5	13,5	14,5	18,6	31,2	27,2	20,0
15	M22 x 1,0	27,5	16,2	15,5	19,5	37,2	28,7	24,5
17	M25 x 1,0	31,0	19,4	16,1	20,3	40,2	30,4	26,7
19	M28 x 1,0	34,0	21,8	16,8	20,8	44,7	32,0	27,0
21	M31 x 1,0	37,0	25,1	17,1	21,7	49,2	33,6	30,5
23	M34 x 1,0	40,0	28,2	17,7	22,0	51,7	35,1	31,5
25	M37 x 1,0	43,5	31,4	18,4	22,9	53,2	36,6	28,5

TABLE 2

ENTRY SIZE	ØG MIN	H LENGTH	J LENGTH	CABLE DIA RANGE
05	7,9	60	40	4,5 – 9,0
08	12,7	60	40	6,0 – 12,0
10	15,8	72	48	7,5 – 15,0
12	19,0	72	48	9,0 – 18,0
16	25,4	95	55	10,0 – 25,0
20	31,8	125	70	12,5 – 30,0
24	38,1	125	70	15,0 – 36,0



TABLE 3

CODE	FINISH
C	ELECTROLESS NICKEL
B	CADMIUM OLIVE DRAB OVER ELECTROLESS NICKEL
ZB	ZINC COBALT OLIVE DRAB OVER ELECTROLESS NICKEL
ZN	ZINC NICKEL BLACK PASSIVATE OVER ELECTROLESS NICKEL

LIST NOT EXHAUSTIVE, SEE PLATING TABLE FOR OTHER OPTIONS

TAKH1-17-08-1-C-SB

SERIES _____
 CONNECTOR INTERFACE _____
 ANGLE _____
 SHELL SIZE (TABLE 1) _____
 ENTRY SIZE (TABLE 2) _____
 MATERIAL _____
 ALUMINIUM ALLOY
 FINISH (TABLE 3) _____
 UB - UNSCREENED BOOT _____
 SB - SCREENED BOOT

DRAWN	J.CLARK	DATE 04/10/2010	 3RD ANGLE PROJECTION NOT TO SCALE	 POLAMCO WESTON LOCK LOWER BRISTOL ROAD BATH BA2 1EP	PAGE 2 OF 2	UNLESS OTHERWISE SPECIFIED ALL DIMENSIONS IN MILLIMETRES
SALES APPR			THIS DRAWING IS COPYRIGHTED THE PROPERTY OF POLAMCO LTD IT MUST NOT BE COPIED, USED FOR MANUFACTURE OR OTHERWISE DISCLOSED WITHOUT PRIOR WRITTEN CONSENT OF THE COMPANY.	ASSY USED ON: MIL-DTL-38999 SERIES III & IV		MATERIAL ALUMINIUM ALLOY 6262
DESIGN APPR	K.SHEP	25/05/2009		TITLE: HEAT SHRINK BACKSHELL KIT		
QUAL APPR				PART NUMBER: TAKH SERIES		DRAWING NO: P13852
ISSUE 4	DCR 3969					
WEIGHT	GENERAL TOL LINEAR +/-0.1MM ANGULAR +/- 1°					